

S-line forwarding trailers

Technical specification

Forwarding trailers	S6	S8
Frame structure	bolted double frame	
Bogie axle	•	•
Front grille area	1.40 m ²	1.79 m ²
Long flat bed	3,500 mm	3,710 mm
Hydraulic Pivoting drawbar with 2 cylinders	•	•
Stanchion pairs	3 + 1	3 + 1
Payload on private roads	6 t	6 t
Permissible gross weight on public roads	up to 6 t	up to 8 t
Empty weight with crane	approx. 1.7 t	approx. 2.2 t
Lighting	according to StVZO, integrated in frame, retractable	
Operating station on draw bar	•	•
Braking system	2-Wheel hydraulic brake	
Brake surface	300x60 mm, 6-hole rim	300x60 mm, 6-hole rim
Tyres	380/55-17" 14 PR, grooved profile	
Rim with valve protection	•	•
Loading crane	LK 2764	LK 3767
Reach	6,340 mm	6,700 mm
Lifting torque net	27 kNm	35 kNm
Pivoting torque	8.1 kNm	11.9 kNm
Crane control	8-fold mechanical, 2 cross levers with 2 electrical functions (rocker) for gripper and telescope	
Double clam shell gripper	• Pm 150	• Pm 230
Crane inspection and initial acceptance, incl. inspection logbook	•	•
Range of accessories	S6	S8
Hydraulics		
Own oil supply (axial piston pump)	○ (63 litres)	○ (63 litres)
Tyres		
480/45-17" groove profile with valve protection	–	○
Braking and drive systems		
4-wheel hydraulic brake	–	○
2-wheel overrun brake with 2-wheel hydraulic brake system	○	○
2-wheel air brake system incl. hydraul. Braking system		○
Loading crane		
Crane cable winch mounted on the front grille, pulling force 1.5 t	○	○
Crane operating hours counter	○	○
LED working lights in the crane arm	–	○
Frame and construction		
Stanchion pair insertion in the rear	○	○
High-sided floor pan	○	○

• Standard ○ Option – Not available

Start your configuration now.
configurator.pfanzelt.com



S-line forwarding trailers

Dimensions

S-line forwarding trailers S6

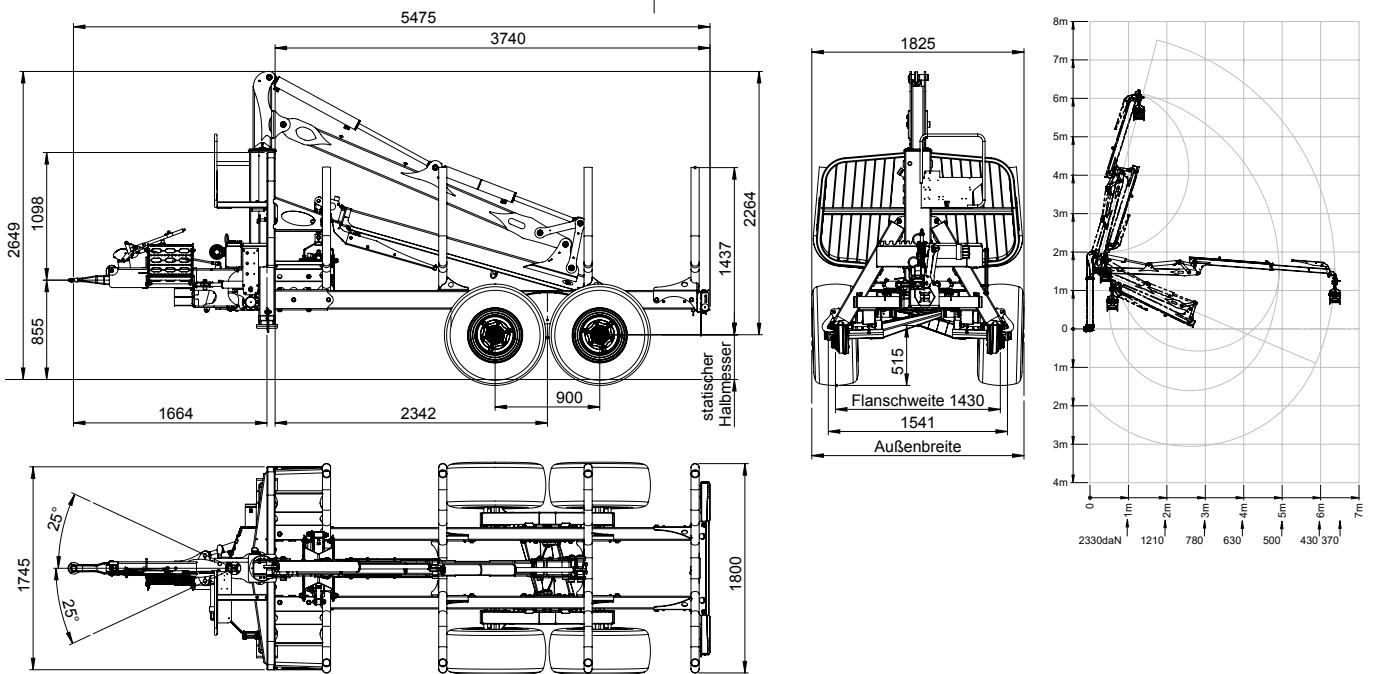

S-line forwarding trailers S8

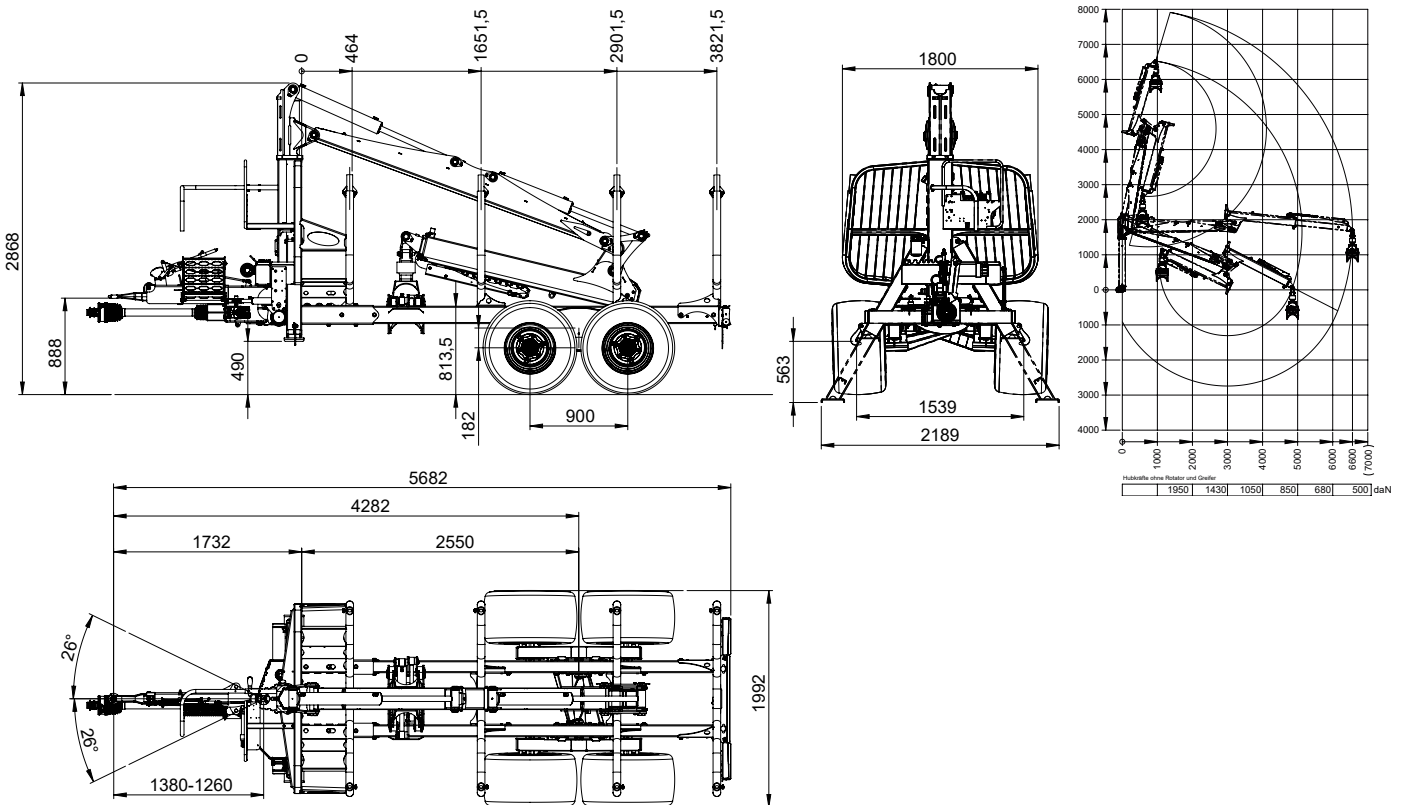

Shown with tyres 480/45-17"